

CLASS- I

ENGLISH

TERM- I

POEM 1: A HAPPY CHILD

I. ERC

1. “My house is red – a little house;
A happy child am I.”

i) My house is red.

a. Pink

b. Blue

c. Red

ii) I am a happy child.

a. Bad

b. Happy

c. Good

2. “I have a tree, a green, green tree,
To shade me from the sun;

i) ‘I’ refers to a child.

a. Sun

b. tree

c. child

ii) Tree gives shade.

a. Tree

b. sun

c. child

LN1. THREE LITTLE PIGS

I. New words

- | | | | | |
|-----------|----------|-----------|----------|----------|
| 1. Little | 2. Stick | 3. House | 4. Brick | 5. Blow |
| 6. Straw | 7. Happy | 8. Strong | 9. Huff | 10. Puff |

II. Opposites

- | | | |
|----------|---|------|
| 1. Up | x | Down |
| 2. Good | x | Bad |
| 3. Happy | x | Sad |
| 4. Come | x | Go |
| 5. Small | x | Big |

III. Past tense

- | | | |
|---------|---|--------|
| 1. Huff | - | Huffed |
| 2. Puff | - | Puffed |
| 3. Live | - | Lived |
| 4. Blow | - | Blew |
| 5. Come | - | Came |

IV. Plurals

- | | | |
|----------|---|--------|
| 1. House | - | Houses |
| 2. Stick | - | Sticks |
| 3. Brick | - | Bricks |
| 4. Pig | - | Pigs |
| 5. Straw | - | Straw |

V. Frame Sentence

1. **Big** : I have a **big** ball.
2. **Live**: I **live** in a house.

VI. Q/A

1. How many pigs were there?
There were three little pigs.
2. Who went away?
The wolf went away.

LN2:THE BUBBLE, THE STRAW AND THE SHOE

I. New words

- | | | | | |
|-----------|------------|-----------|----------|----------|
| 1. Bubble | 2. Shoe | 3. Forest | 4. River | 5. Cross |
| 6. Float | 7. Stretch | 8. Jump | 9. Water | 10. Loud |

II. Opposites

- | | | |
|----------|---|-------|
| 1. Loud | x | Soft |
| 2. Long | x | Short |
| 3. Here | x | There |
| 4. Stand | x | Sit |
| 5. Live | x | Die |

III. Past Tense

- | | | |
|------------|---|-----------|
| 1. Go | - | Went |
| 2. Fall | - | Fell |
| 3. Cross | - | Crossed |
| 4. Jump | - | Jumped |
| 5. Stretch | - | Stretched |

IV. Plurals

- | | | |
|-----------|---|---------|
| 1. Bubble | - | Bubbles |
| 2. Shoe | - | Shoes |
| 3. River | - | Rivers |
| 4. Water | - | Water |
| 5. Forest | - | Forests |

V. Frame Sentence

- Friend:** Straw is my **friend**.
- Forest:** Lion lives in the **forest**.

VI. Q/A

- Name the three friends.
Bubble, Straw and Shoe were friends.
- Where did they go?
They went to the forest.

LN3: LALU AND PEELU

I. New words

- | | | | | |
|-----------|----------|-----------|-----------|-----------|
| 1. Hen | 2. Chick | 3. Thing | 4. Yellow | 5. Plant |
| 6. Chilli | 7. Mouth | 8. Mother | 9. Bring | 10. Laddu |

II. Opposites

- | | | |
|----------|---|------|
| 1. Hot | x | Cold |
| 2. Start | x | Stop |
| 3. Love | x | Hate |
| 4. Yes | x | No |
| 5. Give | x | Take |

III.Past Tense

- | | | |
|----------|---|---------|
| 1. See | - | Saw |
| 2. Love | - | Loved |
| 3. Eat | - | Ate |
| 4. Say | - | Said |
| 5. Start | - | Started |

IV.Plurals

- | | | |
|----------|---|--------|
| 1. Hen | - | Hens |
| 2. Chick | - | Chicks |
| 3. Thing | - | Things |
| 4. Laddu | - | Laddus |
| 5. Plant | - | Plants |

V.Frame Sentence

1. **Laddu:** I like to eat **laddu.**
2. **Mother:** I love my **mother.**

VI.Q/A

1. Who were the chicks?
The chicks were Lалу and Peelu.
2. Who brought a Laddu?
Peelu brought a Laddu.

PM 4: ONCE I SAW A LITTLE BIRD

I. E. R. C.

1. “Once I saw a little bird
Come hop, hop ,hop ”

a. The boy saw a little bird.

i. big

ii. little

iii. black

b. He wanted the bird to hop-hop.

i. fly-fly

ii. cry-cry

iii. hop-hop

2. “ I was going to the window
To say , “ How do you do?”.

a. “I” refers to a boy.

i) Bird

ii) boy

iii) girl

b. The boy was going to the window.

i) House

ii) window

iii) door

LN 4 : MITTU AND THE YELLOW MANGO

I. New words

- | | | | | |
|----------|-----------|------------|----------|-----------|
| 1. Mittu | 2. Parrot | 3. Look | 4. Mango | 5. Tree |
| 6. Crow | 7. Voice | 8. Balloon | 9. Beak | 10. Yummy |

II. Opposites

- | | | |
|------------|---|----------|
| 1. Like | x | Dislike |
| 2. Front | x | Back |
| 3. Pick | x | Drop |
| 4. Always | x | Never |
| 5. Careful | x | Careless |

III. Past tense

- | | | |
|----------|---|---------|
| 1. Fly | - | Flew |
| 2. Like | - | Liked |
| 3. Shout | - | Shouted |
| 4. Make | - | Made |
| 5. Want | - | Wanted |

IV. Plurals

- | | | |
|------------|---|----------|
| 1. Parrot | - | Parrots |
| 2. Mango | - | Mangoes |
| 3. Tree | - | Trees |
| 4. Balloon | - | Balloons |
| 5. Crow | - | Crows |

V. Frame Sentence

1. **Mango:** Mango is very sweet.
2. **Balloon:** I blow a balloon.

VI. Q/A

1. Who was Mittu?
Mittu was a parrot.

2. What did Mittu see under the tree?
Mittu saw a red balloon under the tree.

LN 5: CIRCLE

I. New Words:

- | | | | | |
|----------------|-----------|---------|------------|-----------|
| 1. Grandmother | 2. Circle | 3. Draw | 4. Clap | 5. Rabbit |
| 6. Moon | 7. Wheel | 8. Face | 9. Zig-zag | 10. Line |

II. Opposites

- | | | |
|-----------|---|------|
| 1. Few | x | Many |
| 2. Later | x | Soon |
| 3. Sorrow | x | Joy |
| 4. First | x | Last |
| 5. Under | x | On |

III. Past tense

- | | | |
|---------|---|---------|
| 1. Draw | - | Drew |
| 2. Add | - | Added |
| 3. Look | - | Looked |
| 4. Clap | - | Clapped |
| 5. Ask | - | Asked |

IV. Plurals

- | | | |
|-----------|---|---------|
| 1. Line | - | Lines |
| 2. Wheel | - | Wheels |
| 3. Circle | - | Circles |
| 4. Face | - | Faces |
| 5. Rabbit | - | Rabbits |

V. Frame Sentence

1. **Draw :** I like to draw cartoons.
2. **Rabbit:** Rabbit eats carrot.

VI. Q/A

1. What did Mohini draw first?
Mohini drew a circle first.
2. What were the colours of the balloons?
The colours of the balloons were red, blue, green and yellow.

TERM - II

PM 6: IF I WERE AN APPLE

I. ERC

1. “If I were an apple
And grew on a tree.”

a. Apple grew on trees.

i. trees

ii. plants

iii. climbers

b. ‘I’ refers to the boy.

i. boy

ii. apple

iii. tree

2. “I think I’d drop down,
On a nice boy like me.”

a. The apple drops on a nice boy.

i. bad

ii. naughty

iii. nice

b. The opposite of the word “drop” is carry.

i. put

ii. carry

iii. take

LN 6: OUR TREE

I. New words

- | | | | | |
|-----------|-----------|-----------|----------|------------|
| 1. Fruit | 2. Tasty | 3. Berry | 4. Seeds | 5. Cloud |
| 6. Branch | 7. Spider | 8. Monkey | 9. Web | 10. Pretty |

II. Opposites

- | | | |
|--------------|---|-------|
| 1. Strong | x | Weak |
| 2. Tall | x | Short |
| 3. Little | x | Big |
| 4. Rich | x | Poor |
| 5. Beautiful | x | Ugly |

III. Past Tense

- | | | |
|----------|---|---------|
| 1. Pluck | - | Plucked |
| 2. Run | - | Ran |
| 3. Perch | - | Perched |
| 4. Crawl | - | Crawled |
| 5. Sing | - | Sang |

IV. Plurals

- | | | |
|-----------|---|----------|
| 1. Branch | - | Branches |
| 2. Seed | - | Seeds |
| 3. Fruit | - | Fruits |
| 4. Leg | - | Legs |
| 5. Web | - | Webs |

V. Frame Sentence

1. **Tasty :** My mother cooks tasty food.
2. **Sing:** I like to sing.

VI.Q/A

1. Where do birds live?
Birds live on a tree.
2. What fruit does the bird eat?
The bird eats a tasty berry fruit.

LN 7: SUNDARI

I. New words

- | | | | | |
|----------|----------|-----------|------------|-----------|
| 1. Smile | 2. White | 3. Fair | 4. Animals | 5. Space |
| 6. Grass | 7. Leap | 8. String | 9. Hard | 10. Round |

II. Opposites

- | | | |
|----------|---|-------|
| 1. Open | x | Close |
| 2. Hard | x | Soft |
| 3. High | x | Low |
| 4. Near | x | Far |
| 5. Smile | x | Cry |

III. Past Tense

- | | | |
|----------|---|--------|
| 1. Cry | - | Cried |
| 2. Hold | - | Held |
| 3. Smile | - | Smiled |
| 4. Tune | - | Tuned |
| 5. Take | - | Took |

IV. Plurals

- | | | |
|-----------|---|---------|
| 1. Animal | - | Animals |
| 2. Boy | - | Boys |
| 3. Girl | - | Girls |
| 4. Kite | - | Kites |
| 5. Grass | - | Grasses |

V. Frame Sentence

1. **Kite** : Kite flies in the sky.
2. **Play** : I like to play cricket.

VI. Q/A

1. Who was Sundari?
Sundari was a kite.
2. Who made Sundari?
Bobby made Sundari.
3. Did Sundari fly high?
Yes, Sundari flew high.

PM 8: A LITTLE TURTLE

I. ERC:

1. “I am a little turtle
I crawl so slow.”

a. I am a little turtle.

i. flower

ii. turtle

iii. frog

b. The turtle crawls slow.

i. slow

ii. fast

iii. down

2. “When I get tired
I put in my head.”

a. The turtle gets tired.

i) Turtle

ii) frog

iii) rabbit

b. The turtle goes to the bed.

i) Bed

ii) house

iii) forest

LN 8: THE TIGER AND THE MOSQUITO

I. New words

- | | | | | |
|----------|-------------|------------|-----------|------------|
| 1. Tiger | 2. Mosquito | 3. Buzzing | 4. Afraid | 5. Cheek |
| 6. Angry | 7. Quiet | 8. Paw | 9. Struck | 10. Friend |

II. Opposites

- | | | |
|-------------|---|-------|
| 1. Angry | x | Calm |
| 2. Begin | x | End |
| 3. Friend | x | Enemy |
| 4. Everyone | x | None |
| 5. Quiet | x | Loud |

III. Past tense

- | | | |
|----------|---|--------|
| 1. Begin | - | Began |
| 2. Hit | - | Hit |
| 3. Call | - | Called |
| 4. Buzz | - | Buzzed |
| 5. Shall | - | Should |

IV. Plurals

- | | | |
|-------------|---|------------|
| 1. Tiger | - | Tigers |
| 2. Mosquito | - | Mosquitoes |
| 3. Cheek | - | Cheeks |
| 4. Leaf | - | Leaves |
| 5. Tooth | - | Teeth |

V. Frame Sentence

1. **Tiger:** Tiger is our national animal.
2. **Proud:** I feel proud of my country.

VI. Q/A

1. What was the tiger doing under the tree?
The tiger was dozing under the tree.
2. What is the moral of the lesson?
Everyone is great in their own way.

LN 9: ANANDI'S RAINBOW

I. New words

- | | | | | |
|-----------|------------|--------------|------------|-----------|
| 1. Dream | 2. Rainbow | 3. Favourite | 4. Flower | 5. Garden |
| 6. Bright | 7. Shine | 8. Glory | 9. Colours | 10. Clear |

II. Opposites

- | | | |
|------------|---|--------|
| 1. Bright | x | Dull |
| 2. Fast | x | Slow |
| 3. Huge | x | Small |
| 4. Outside | x | Inside |
| 5. Before | x | After |

III. Past tense

- | | | |
|-----------|---|----------|
| 1. Give | - | Gave |
| 2. Leave | - | Left |
| 3. Want | - | Wanted |
| 4. Paint | - | Painted |
| 5. Colour | - | Coloured |

IV. Plurals

- | | | |
|-----------|---|---------|
| 1. Colour | - | Colours |
| 2. Garden | - | Gardens |
| 3. Cat | - | Cats |
| 4. Flower | - | Flowers |
| 5. Sky | - | Skies |

V. Frame Sentence

1. Sun: The Sun rises in the east.
2. Yellow: Mango is yellow in colour.

VI. Q/A

1. Who was dreaming about the Rainbow?
Anandi was dreaming about the Rainbow.
2. What are the colours of rainbow?
The colours of rainbow are Violet, Indigo, Blue, Green, Yellow, Orange and Red.

LN10 : THE TAILOR AND HIS FRIEND

I. New words:

- | | | | | |
|-----------|-----------|-------------|-------------|----------|
| 1. Tailor | 2. Shirt | 3. Children | 4. Elephant | 5. Trunk |
| 6. Cloth | 7. Forget | 8. Reach | 9. Pant | 10. Shop |

II. Opposites:

- | | | |
|-------------|---|--------|
| 1. Near | x | Far |
| 2. Remember | x | Forget |
| 3. Empty | x | Full |
| 4. Old | x | New |
| 5. Good | x | Bad |

III. Past tense:

- | | | |
|-----------|---|---------|
| 1. Throw | - | Threw |
| 2. Reach | - | Reached |
| 3. Play | - | Played |
| 4. Become | - | Became |
| 5. Forget | - | Forgot |

IV. Plurals:

- | | | |
|-----------|---|----------|
| 1. Needle | - | Needles |
| 2. Shirt | - | Shirts |
| 3. Shop | - | Shops |
| 4. Child | - | Children |
| 5. Tailor | - | Tailors |

V. Frame Sentence:

1. **Shop:** I go to shop to buy a pen.
2. **Dress:** I bought a new dress.

VI. Q/A:

1. Where was Kalu's shop?
Kalu's shop was near the river.
2. Who became good friends?
Appu and Kalu became good friends.

CREATIVE WRITING:

1. PICTURE COMPOSITION (WRITING)

Look at the picture and write 5 sentences about it.

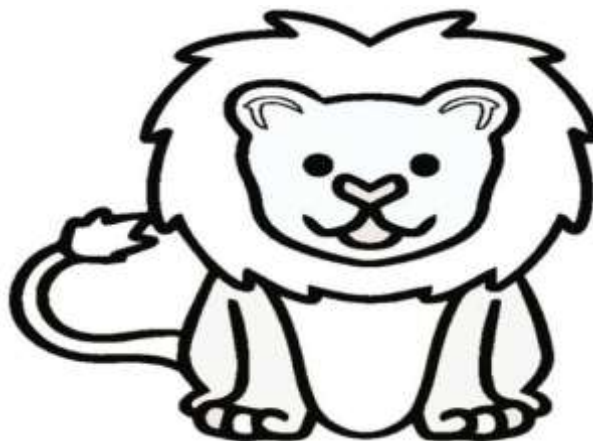

1. This is a lion.
2. It is yellow in colour.
3. It eats meat.
4. It lives in the forest.
5. It is a wild animal.

2. GUIDED COMPOSITION: (WRITING)

1. This is Balu's pencil box.
2. It is red in colour.
3. His father bought it for him.
4. He brings it to school dai ly.
5. He likes it very much.

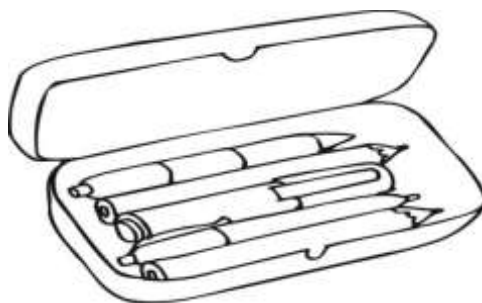

Now write similar sentences about your pencil box :

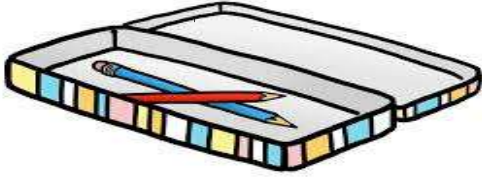

1. This is my pencil box.
2. It is green in colour
3. My father bought it for me
4. I bring it to school daily.
5. I like it very much.

3. PICTURE COMPOSITION (WRITING)

Look at the picture and write 5 sentences about it.



1. This is an apple.
2. It is red in colour.
3. It has few seeds.
4. It is very sweet.
5. It like it very much.

4.. COMPREHENSION: (READING)

The Goose and its golden egg



Once there lived a poor farmer. He had a goose. It laid a golden egg every day. The farmer sold the eggs and became rich. He was a greedy farmer. He wanted all the golden eggs at the same time. So he took a knife and cut the goose but there were no eggs in it. Thus the greedy farmer lost both the goose and the golden eggs and became poor again.

Answer the following:

1. What did the farmer have?

A. The farmer had a goose.

2. What did it lay every day?

A. It laid a golden egg every day.

3. How did the farmer become rich?

A. The farmer sold the eggs and became rich.

4. Who lost both the goose and the golden eggs?

A. The greedy farmer.

5. PICTURE COMPOSITION (WRITING)

Look at the picture and write 5 sentences about it.

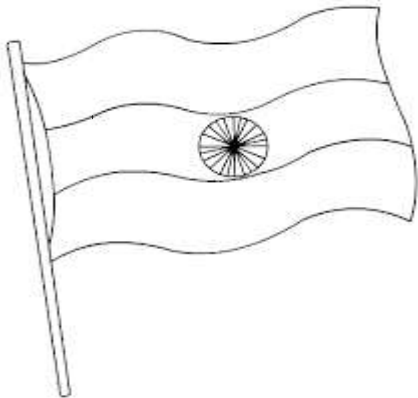

1. This is our National Flag.
2. It has three colours.
3. They are saffron, white and green.
4. An Ashoka Chakra is in the middle.
5. I respect our national flag.

6. STORY WRITING:



thirsty	big
little	clever
round	cool
happy	bottom

Kaku, the crow, is very thirsty. He sees a big pot with a little water at the bottom. The clever crow drops round pebbles into the pot. The cool water comes up, the crow sips it and felt happy.