

CLASS- I

ENGLISH

TERM- I

POEM 1: A HAPPY CHILD

I. ERC

1. “My house is red – a little house;
A happy child am I.”

i) My house is red.

a. Pink

b. Blue

c. Red

ii) I am a happy child.

a. Bad

b. Happy

c. Good

2. “I have a tree, a green, green tree,
To shade me from the sun; ”

i) Whom does “I” refer to?

I refers to a **child**.

ii) Who gives shade?

Tree gives shade.

LN1. THREE LITTLE PIGS

I. New words

- | | | | | |
|-----------|----------|-----------|----------|----------|
| 1. Little | 2. Stick | 3. House | 4. Brick | 5. Blow |
| 6. Straw | 7. Happy | 8. Strong | 9. Huff | 10. Puff |

II. Opposites

- | | | |
|----------|---|------|
| 1. Up | x | Down |
| 2. Good | x | Bad |
| 3. Happy | x | Sad |
| 4. Come | x | Go |
| 5. Small | x | Big |

III. Past tense

- | | | |
|---------|---|--------|
| 1. Huff | - | Huffed |
| 2. Puff | - | Puffed |
| 3. Live | - | Lived |
| 4. Blow | - | Blew |
| 5. Come | - | Came |

IV. Plurals

- | | | |
|----------|---|--------|
| 1. House | - | Houses |
| 2. Stick | - | Sticks |
| 3. Brick | - | Bricks |
| 4. Pig | - | Pigs |
| 5. Straw | - | Straw |

V. Frame Sentence

1. **Big** : I have a **big** ball.
2. **Live**: I **live** in a house.

VI. Q/A

1. How many pigs were there?
There were three little pigs.
2. Who went away?
The Wolf went away.

LN2:THE BUBBLE, THE STRAW AND THE SHOE

I. New words

- | | | | | |
|-----------|------------|-----------|----------|----------|
| 1. Bubble | 2. Shoe | 3. Forest | 4. River | 5. Cross |
| 6. Float | 7. Stretch | 8. Jump | 9. Water | 10. Loud |

II. Opposites

- | | | |
|----------|---|-------|
| 1. Loud | x | Soft |
| 2. Long | x | Short |
| 3. Here | x | There |
| 4. Stand | x | Sit |
| 5. Live | x | Die |

III. Past Tense

- | | | |
|------------|---|-----------|
| 1. Go | - | Went |
| 2. Fall | - | Fell |
| 3. Cross | - | Crossed |
| 4. Jump | - | Jumped |
| 5. Stretch | - | Stretched |

IV. Plurals

- | | | |
|-----------|---|---------|
| 1. Bubble | - | Bubbles |
| 2. Shoe | - | Shoes |
| 3. River | - | Rivers |
| 4. Water | - | Water |
| 5. Forest | - | Forests |

V. Frame Sentence

- Friend:** Straw is my **friend**.
- Forest:** Lion lives in the **forest**.

VI. Q/A

- Name the three friends.
Bubble, Straw and Shoe were friends.
- Where did they go?
They went to the forest.

LN3: LALU AND PEELU

I. New words

- | | | | | |
|-----------|----------|-----------|-----------|-----------|
| 1. Hen | 2. Chick | 3. Thing | 4. Yellow | 5. Plant |
| 6. Chilli | 7. Mouth | 8. Mother | 9. Bring | 10. Laddu |

II. Opposites

- | | | |
|----------|---|------|
| 1. Hot | x | Cold |
| 2. Start | x | Stop |
| 3. Love | x | Hate |
| 4. Yes | x | No |
| 5. Give | x | Take |

III. Past Tense

- | | | |
|----------|---|---------|
| 1. See | - | Saw |
| 2. Love | - | Loved |
| 3. Eat | - | Ate |
| 4. Say | - | Said |
| 5. Start | - | Started |

IV. Plurals

- | | | |
|----------|---|--------|
| 1. Hen | - | Hens |
| 2. Chick | - | Chicks |
| 3. Thing | - | Things |
| 4. Laddu | - | Laddus |
| 5. Plant | - | Plants |

V. Frame Sentence

1. **Laddu:** I like to eat **laddu.**
2. **Mother:** I love my **mother.**

I.Q/A

1. Who were the chicks?
The chicks were lalu and Peelu.
2. Who brought a Laddu?
Peelu brought a Laddu.

PM 4: ONCE I SAW A LITTLE BIRD

I. E. R. C.

1. “Once I saw a little bird
Come hop, hop ,hop ”

a. The boy saw a little bird.

i. Big

ii. Little

iii. Black

b. He wanted the bird to hop-hop.

i. Fly-fly

ii. Cry-cry

iii. Hop-hop

2. “ I was going to the window
To say , “ How do you do?”.

a. Whom does “I” refer to?

“I” refers to a **boy**.

b. Where was he going?

He was going to the window.

LN 4 : MITTU AND THE YELLOW MANGO

I. New words

- | | | | | |
|----------|-----------|------------|----------|-----------|
| 1. Mittu | 2. Parrot | 3. Look | 4. Mango | 5. Tree |
| 6. Crow | 7. Voice | 8. Balloon | 9. Beak | 10. Yummy |

II. Opposites

- | | | |
|------------|---|----------|
| 1. Like | x | Dislike |
| 2. Front | x | Back |
| 3. Pick | x | Drop |
| 4. Always | x | Never |
| 5. Careful | x | Careless |

III. Past tense

- | | | |
|----------|---|---------|
| 1. Fly | - | Flew |
| 2. Like | - | Liked |
| 3. Shout | - | Shouted |
| 4. Make | - | Made |
| 5. Want | - | Wanted |

IV. Plurals

- | | | |
|------------|---|----------|
| 1. Parrot | - | Parrots |
| 2. Mango | - | Mangoes |
| 3. Tree | - | Trees |
| 4. Balloon | - | Balloons |
| 5. Crow | - | Crows |

V. Frame Sentence

1. **Mango:** Mango is very sweet.
2. **Balloon:** I blow balloon.

VI. Q/A

1. Who was Mittu?
Mittu was a parrot.

2. What did Mittu see under the tree?
Mittu saw a red balloon under the tree.

LN 5: CIRCLE

I. New Words:

- | | | | | |
|----------------|-----------|---------|------------|-----------|
| 1. Grandmother | 2. Circle | 3. Draw | 4. Clap | 5. Rabbit |
| 6. Moon | 7. Wheel | 8. Face | 9. Zig-zag | 10. Line |

II. Opposites

- | | | |
|-----------|---|------|
| 1. Few | x | Many |
| 2. Later | x | Soon |
| 3. Sorrow | x | Joy |
| 4. First | x | Last |
| 5. Under | x | On |

III. Past tense

- | | | |
|---------|---|---------|
| 1. Draw | - | Drew |
| 2. Add | - | Added |
| 3. Look | - | Looked |
| 4. Clap | - | Clapped |
| 5. Ask | - | Asked |

IV. Plurals

- | | | |
|-----------|---|---------|
| 1. Line | - | Lines |
| 2. Wheel | - | Wheels |
| 3. Circle | - | Circles |
| 4. Face | - | Faces |
| 5. Rabbit | - | Rabbits |

V. Frame Sentence

1. **Draw :** I like to draw cartoons.
2. **Rabbit:** Rabbit eats carrot.

VI. Q/A

1. What did Mohini draw first?
Mohini drew a circle first.
2. What were the colours of the balloons?
The colours of the balloons were red, blue, green and yellow.

TERM - II

PM 6: IF I WERE AN APPLE

I. ERC

1. “If I were an apple
And grew on a tree.”

a. Apple grew on trees.

i. Trees

ii. Plants

iii. Climbers

b. ‘I’ refers to the boy.

i. Boy

ii. Apple

iii. Tree

2. “I think I’d drop down,
On a nice boy like me.”

a. The apple drops on a nice boy.

i. Bad

ii. Naughty

iii. Nice

b. The opposite of the word “drop” is carry.

i. Put

ii. Carry

iii. Take

LN 6: OUR TREE

I. New words

- | | | | | |
|-----------|-----------|-----------|----------|------------|
| 1. Fruit | 2. Tasty | 3. Berry | 4. Seeds | 5. Cloud |
| 6. Branch | 7. Spider | 8. Monkey | 9. Web | 10. Pretty |

II. Opposites

- | | | |
|--------------|---|-------|
| 1. Strong | x | Weak |
| 2. Tall | x | Short |
| 3. Little | x | Big |
| 4. Rich | x | Poor |
| 5. Beautiful | x | Ugly |

III. Past Tense

- | | | |
|----------|---|---------|
| 1. Pluck | - | Plucked |
| 2. Run | - | Ran |
| 3. Perch | - | Perched |
| 4. Crawl | - | Crawled |
| 5. Sing | - | Sang |

IV. Plurals

- | | | |
|-----------|---|----------|
| 1. Branch | - | Branches |
| 2. Seed | - | Seeds |
| 3. Fruit | - | Fruits |
| 4. Leg | - | Legs |
| 5. Web | - | Webs |

V. Frame Sentence

1. **Tasty :** My mother cooks tasty food.
2. **Sing:** I like to sing.

VII.Q/A

1. Where do birds live?
Birds live in a forest.
2. What fruit does the bird eat?
The bird eats a tasty berry fruit.

LN 7: SUNDARI

I. New words

- | | | | | |
|----------|----------|-----------|------------|-----------|
| 1. Smile | 2. White | 3. Fair | 4. Animals | 5. Space |
| 6. Grass | 7. Leap | 8. String | 9. Hard | 10. Round |

II. Opposites

- | | | |
|----------|---|-------|
| 1. Open | x | Close |
| 2. Hard | x | Soft |
| 3. High | x | Low |
| 4. Near | x | Far |
| 5. Smile | x | Cry |

III. Past Tense

- | | | |
|----------|---|--------|
| 1. Cry | - | Cried |
| 2. Hold | - | Held |
| 3. Smile | - | Smiled |
| 4. Tune | - | Tuned |
| 5. Take | - | Took |

IV. Plurals

- | | | |
|-----------|---|---------|
| 1. Animal | - | Animals |
| 2. Boy | - | Boys |
| 3. Girl | - | Girls |
| 4. Kite | - | Kites |
| 5. Grass | - | Grasses |

V. Frame Sentence

1. **Kite** : Kite flies in the sky.
2. **Play** : I like to play cricket.

VI. Q/A

1. Who is Sundari?
Sundari is a kite.
2. Who made Sundari?
Bobby made Sundari.
3. Did Sundari fly high?
Yes, Sundari flew high.

PM 8: A LITTLE TURTLE

I. ERC:

1. “I am a little turtle
I crawl so slow.”

a. I am a little turtle.

i. Flower

ii. Turtle

iii. Frog

b. The turtle crawls slow.

i. Slow

ii. Fast

iii. Down

2. “When I get tired
I put in my head.”

a. Who got tired?

Turtle got tired.

b. Where did the turtle go?

The turtle went to the bed.

LN 8: THE TIGER AND THE MOSQUITO

I. New words

- | | | | | |
|----------|-------------|------------|-----------|------------|
| 1. Tiger | 2. Mosquito | 3. Buzzing | 4. Afraid | 5. Cheek |
| 6. Angry | 7. Quiet | 8. Paw | 9. Scrap | 10. Friend |

II. Opposites

- | | | |
|-------------|---|-------|
| 1. Angry | x | Calm |
| 2. Begin | x | End |
| 3. Friend | x | Enemy |
| 4. Everyone | x | None |
| 5. Quiet | x | Loud |

III. Past tense

- | | | |
|----------|---|---------|
| 1. Begin | - | Began |
| 2. Scrap | - | Scraped |
| 3. Call | - | Called |
| 4. Buzz | - | Buzzed |
| 5. Shall | - | Should |

IV. Plurals

- | | | |
|-------------|---|------------|
| 1. Tiger | - | Tigers |
| 2. Mosquito | - | Mosquitoes |
| 3. Cheek | - | Cheeks |
| 4. Leaf | - | Leaves |
| 5. Tooth | - | Teeth |

V. Frame Sentence

1. **Tiger:** Tiger is our national animal.
2. **Proud:** I feel proud.

VI. Q/A

1. What was the tiger doing under the tree?
The tiger was dozing under the tree.
2. What is the moral of the lesson?
Everyone is great in his own way.

LN 9: ANANDHI'S RAINBOW

I. New words

- | | | | | |
|-----------|------------|--------------|------------|-----------|
| 1. Dream | 2. Rainbow | 3. Favourite | 4. Flower | 5. Garden |
| 6. Bright | 7. Shine | 8. Glory | 9. Colours | 10. Clear |

II. Opposites

- | | | |
|------------|---|--------|
| 1. Bright | x | Dull |
| 2. Fast | x | Slow |
| 3. Huge | x | Small |
| 4. Outside | x | Inside |
| 5. Before | x | After |

III. Past tense

- | | | |
|-----------|---|----------|
| 1. Give | - | Gave |
| 2. Leave | - | Left |
| 3. Want | - | Wanted |
| 4. Paint | - | Painted |
| 5. Colour | - | Coloured |

IV. Plurals

- | | | |
|-----------|---|---------|
| 1. Colour | - | Colours |
| 2. Garden | - | Gardens |
| 3. Cat | - | Cats |
| 4. Flower | - | Flowers |
| 5. Sky | - | Skies |

V. Frame Sentence

1. Sun: The **Sun** rises in the east.
2. Yellow: Mango is **yellow** in colour.

VI. Q/A

1. Who was dreaming about the Rainbow?
Anandhi was dreaming about the Rainbow.
2. What are the colours of rainbow?
The colours of rainbow are Violet, Indigo, Blue, Green, Yellow, Orange and Red.

PM 10: FLYING MAN

I. E. R. C.

1. “Flying-man , Flying- man,
Up in the sky ,
Where are you going to,
Flying so high?”.

a. Whom does ‘you’ refer to?

‘You’ refers to “Flying-man”.

b. Where is he flying?

He is flying up in the sky.

2. “Over the mountains,
And over the sea!”
“Flying-man , Flying- man,
Can’t you take me?”

a. Where does the flying man go?

The flying man goes over the mountain and sea.

b. What does the child want to do?

The child wants to go with flying man.

LN10 : THE TAILOR AND HIS FRIEND

I. New words:

- | | | | | |
|-----------|-----------|-------------|-------------|----------|
| 1. Tailor | 2. Shirt | 3. Children | 4. Elephant | 5. Trunk |
| 6. Cloth | 7. Forget | 8. Reach | 9. Pant | 10. Shop |

II. Opposites:

- | | | |
|-------------|---|--------|
| 1. Near | x | Far |
| 2. Remember | x | Forget |
| 3. Empty | x | Full |
| 4. Old | x | New |
| 5. Good | x | Bad |

III. Past tense:

- | | | |
|-----------|---|---------|
| 1. Throw | - | Threw |
| 2. Reach | - | Reached |
| 3. Play | - | Played |
| 4. Become | - | Became |
| 5. Forget | - | Forgot |

IV. Plurals:

- | | | |
|-----------|---|----------|
| 1. Needle | - | Needles |
| 2. Shirt | - | Shirts |
| 3. Shop | - | Shops |
| 4. Child | - | Children |
| 5. Cloth | - | Clothes |

V. Frame Sentence:

1. **Shop:** I go to shop.
2. **Dress:** I bought a new dress.

VI. Q/A:

1. Where was Kalu's shop?
Kalu's shop was near the river.
2. Who became good friends?
Appu and Kalu became good friends.

CREATIVE WRITING:

1. PICTURE COMPOSITION (WRITING)

See the picture and write 5 sentences:



1. This is a park.
2. It is beautiful.
3. A boy and a girl are playing.
4. There is a swing.
5. I like this park very much

2. GUIDED COMPOSITION: (WRITING)

1. This is Balu's pencil box.
2. It is red in colour.
3. His father bought it for him.
4. He brings it to school dai ly.
5. He likes it very much.

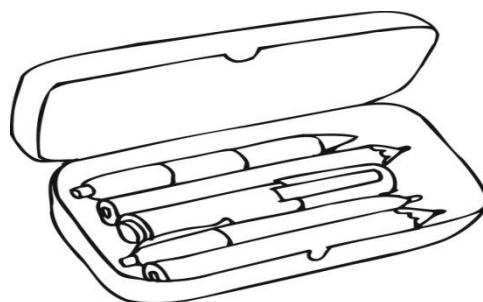

Now write similar sentences about your pencil box :

1. This is my pencil box.
2. It is green in colour
3. My father bought it for me
4. I bring it to school daily.
5. I like it very much.



3. COMPREHENSION: (READING)

The Goose and its golden egg



Once there lived a poor farmer. He had a goose. It laid a golden egg every day. The farmer sold the eggs and became rich. He was a greedy farmer. He wanted all the golden eggs at the same time. So he took a knife and cut the goose but there were no eggs in it. Thus the greedy farmer lost both the goose and the golden eggs and became poor again.

Answer the following:

1. What did the farmer have?

A. The farmer had a goose.

2. What did it lay every day?

A. It laid a golden egg every day.

3. How did the farmer become rich?

A. The farmer sold the eggs and became rich.

4. Who lost both the goose and the golden eggs?

A. The greedy farmer.

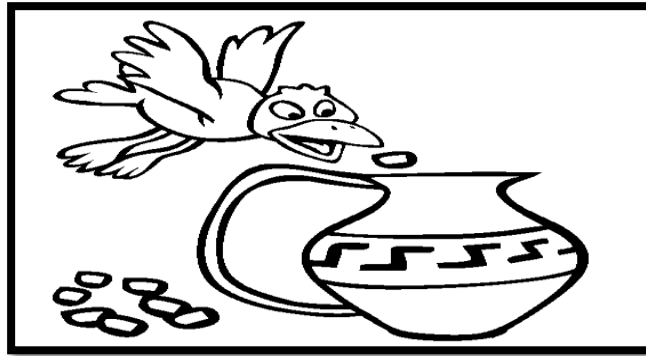
4. STORY WRITING:**thirsty****big****little****clever****round****cool****happy****bottom**

Kaku, the crow, is very **thirsty**. He sees a **big** pot with a **little** water at the **bottom**. The **clever** crow drops **round** pebbles into the pot. The **cool** water comes up, the crow sips it and felt **happy**.