

Lesson.1 – CRICKET OR FOOTBALL?

I.New words

- | | |
|------------|----------|
| 1.Cricket | 6.Bowl |
| 2.Football | 7. Bat |
| 3.Game | 8. Uncle |
| 4.Play | 9.Father |
| 5.Friend | 10. Help |

II.Opposites

- | | | |
|-------------------|----------------|-------------|
| 1. Friend x Enemy | 2. Come x Go | 3. In x Out |
| 4. Happy x Sad | 3. Big x Small | |

III .Past tense

- | | | |
|------------------|------------------|------------------|
| 1. See – saw | 2. Play – played | 3. Stand – stood |
| 4. Help – helped | 5. Run – ran | |

IV.Plurals

- | | | |
|-----------------|-----------------|---------------------|
| 1. Ball – balls | 2. Bat – bats | 3. Friend – friends |
| 4. Shoe – shoes | 5. Game – games | |

V. Frame sentence :

1. Play: I like to play cricket.
2. Friend: Kitu is my friend.

VI. Q/A :

1. Who were friends?

Ans : Jitu and Kitu were friends.

2. Who wants to bowl?

Ans : Jitu wants to bowl.

FIVE HUNGRY DUCKLINGS (POEM)

1. “ There were five hungry ducklings,

Swimming on a lake”.

a) There were _____ hungry ducklings .

i) Three ii) five iii) four

b) They swim in the _____.

i) Lake ii) pond iii) river

2. “ I have to fish for tasty food”.

a) What does ‘ I’ refer to ?

‘ I’ refers to mother duck.

b) Give the meaning of ‘tasty’.

‘tasty’ means ‘sweet’.

LESSON 2 : THE GIRL ON THE TRAIN

I.New words :

- | | |
|----------|------------|
| 1.Wave | 6. Around |
| 2.Train | 7. Window |
| 3.Field | 8. People |
| 4.Past | 9. Mother |
| 5.Breeze | 10. School |

II.Opposites :

- | | | |
|-----------------|-----------------|---------------|
| 1. Few x Many | 2. Stand x sit | 3. Under x on |
| 4. Long x short | 5. Front x back | |

III.Past tense :

- | | | |
|------------------|--------------|----------------|
| 1. Wave – waved | 2. Go – went | 3. Fly – flied |
| 4. Look – looked | 5. Sit – sat | |

IV.Plurals :

- | | | |
|-----------------------|---------------------|-----------------|
| 1. Plant – plants | 2. Bus – buses | 3. Gate – gates |
| 4. Tractor – tractors | 5. Child – children | |

V. Frame sentence :

- 1.Mother: I like my mother.
- 2.Fly: Birds fly in the sky.

VI. Q/A

1.Who were on a train?

Ans : Bindu and her mother were on a train.

2.Who is sitting under a tree?

Ans: A little boy is sitting under a tree.

LESSON 3 A FRIEND FOR MILU

I. NEW WORDS :

- | | |
|--------------|-----------|
| 1. Giraffe | 6. Jerry |
| 2. Monkey | 7. Toothy |
| 3. Tiger | 8. Chandu |
| 4. Crocodile | 9. Chimpu |
| 5. Elephant | 10. Climb |

II. OPPOSITES :

- | | | | |
|-----------------|----------------|-----------------|-----------------|
| 1. Top x bottom | 3. laugh x cry | 2. tall x short | 4. First x last |
| 5. love x hate | | | |

III. PAST TENSE :

- | | | |
|----------------|------------------|-------------------|
| 1. cry - cried | 3. Walk - walked | 5. Smile - smiled |
| 2. can - could | 4. Come - came | |

IV. PLURALS :

- | | | |
|-----------------|------------------|-------------------|
| 1. fish - fish | 3. Tree-trees | 5. Tiger - tigers |
| 2. river-rivers | 4. Leaf - leaves | |

V. FRAME SENTENCE :

1. chase : The cat chased the rat.
2. Busy : I am very busy.

VI. Q/A

1. Who were busy?

Ans : Jerry, Toothy and Chandu were busy .

2. Who helped milu ?

Ans: Chimpu helped milu.

LITTLE THINGS (POEM)

1. “ Little drops of water,

Little grains of sand”

a. The sea is made up of water

(i)water (ii) juice (iii) rocks

b. Land is made up of sand

(i) bus (ii) land (iii) table

2. “make our earth an Eden

Like the heaven above”

a) ‘Heaven’ means a Happy place

(i) sad (ii) happy (iii) miserable

b)The poet wants to make our earth an Eden

(i) an eden (ii) a park (iii) a temple

LESSON-4 THE WORLD OUTSIDE

I NEW WORDS

- | | |
|-------------|-------------|
| 1. Brown | 6. Village |
| 2. Great | 7. Mountain |
| 3. Stream | 8. Seashore |
| 4. Horrible | 9. Farm |
| 5. Nicer | 10. Thirsty |

II. OPPOSITES

- | | | |
|---------------------|------------------|----------------|
| 1. Long x short | 3. Heavy x light | 5. Hard x soft |
| 2. Outside X inside | 4. Top x bottom | |

III. PAST TENSE

- | | | |
|------------------|--------------------|----------------|
| 1. Find – found | 3. Think - thought | 5. Make – made |
| 2. Drink – drank | 4. Walk – walked | |

IV .PLURALS

- | | | |
|-------------------|---------------------|---------------|
| 1. Place – places | 3. Friend – friends | 5. Tap – taps |
| 2. Town – towns | 4. Farm – farms | |

V. Frame sentence :

1. Farm : Cows live in a farm.
2. Thirsty : I feel thirsty in the hot sun.

VI. Q/A:

1. Who were great friends?

Ans : Pat, Nog and How were great friends.

2. Where do they live?

Ans : They live in a farm.

3. Which is salty ?.

Ans : The sea water is salty.

LESSON-5 A PRESENT FOR JITU

1. NEW WORDS

- | | |
|-------------|------------|
| 1. Post man | 6. Flute |
| 2. Packet | 7. Parents |
| 3. Knocks | 8. Card |
| 4. Younger | 9. World |
| 5. Pencil | 10. Heavy |

II. OPPOSITES

- | | | |
|------------------|-----------------|-----------------|
| 1. heavy x light | 3. Open x close | 5. Carry x drop |
| 2. best x worst | 4. Well x ill | |

III. PAST TENSE

- | | | |
|----------------|----------------|-------------|
| 1. give-gave | 3. sign-signed | 5. say-said |
| 2. write-wrote | 4. open-opened | |

IV. PLURALS

- | | | |
|-------------------|-----------------|---------------|
| 1. Packet-packets | 3. Man-men | 5. card-cards |
| 2. sister-sisters | 4. Flute-flutes | |

V. Frame sentence :

1. Gift: My friend gave me a gift.
2. Post man: A post man delivers letter.

VI. Q/A:

1. Who comes to Jitu's house?

Ans : A Post man comes to Jitu's house.

2. What is in the parcel?

Ans : A cricket bat is in the parcel.

LESSON – 6 .KULDEEP’S TREE

I. OPPOSITES :

- | | | |
|---------------|---------------|-----------------|
| 1.Up x down | 3.Big x small | 5.Bless x curse |
| 2.Love x hate | 4.Dry x wet | |

II. PAST TENSE:

- | | | |
|-----------------|---------------|---------------|
| 1.Sleep – slept | 3.Win – won | 5.Sing – sang |
| 2.Cut – cut | 4.Wake – woke | |

III . PLURALS :

- | | | |
|-------------------|--------------------|------------------|
| 1.Mango – mangoes | 3.Child – children | 5.Knife – knives |
| 2.Tree – trees | 4.Leaf – leaves | |

IV. FRAME SENTENCE :

- 1.gift: My father gave me a gift .
- 2.School : I go to school in neat uniform.

V. Q/A :

1. Where is the mango tree?
Ans : The mango tree is in Kuldeep’s garden.
2. Who hides among the leaves?
Ans : Kuldeep hides among the leaves.
3. Which tree is big and shady?
Ans : A mango tree is big and shady.

IF I WERE AN APPLE (poem)

1. “ If I were an apple

And grew upon a tree”.

a. Apples grew on trees

(i) Trees (ii) plants (iii) climbers

b. ‘I’ refers to the boy

(i) Boy (ii) apple (iii) tree

2. “ I think I’d fall down ,

On a good boy like me”.

a. The apple falls on a good boy

(i) Bad (ii) naughty (iii) good

b. The opposite of the word ‘good’ is bad

i)bad ii) happy iii) beautiful

LN – 7 TOMATO SANDWICHES

I. OPPOSITES :

- 1.Clean x dirty \3. Friend x enemy 5.Always x never
2.Polite x harsh 4. Well x ill

II. PAST TENSE :

- 1.Tell – told 3 . Sit – sat 5.Come – came
2. Know – knew 4. Buy – bought

III. PLURALS :

- 1.Tomato – tomatoes 3. Slice – slices 5. Box _ boxes
2.Flower – flowers 4. Banana – bananas

IV. FRAME SENTENCE :

- 1.Evening : I like to play in the evening.
2. Teacher : I respect my teacher.

V. Q/A :

1. What does Rohit want for lunch?

Ans :Rohit wants a tomato sandwich for lunch.

2. What fruit does Mamma put in Rohit's lunch box?

Ans :Mamma puts a banana in Rohit's lunch box.

3. Who gave the little plant to Rohit?

Ans : Rohit's teacher gave the little plant to him.

Creative Writing : picture composition (Writing)

See the picture and write 5 sentences :



1. This is a park.
2. It is beautiful.
3. A boy and a girl are playing.
4. There is a swing.
5. I like this park very much

Guided composition : (Writing)

This is Balu's pencil box.

It is red in colour.

His father bought it for him.

He brings it to school dai ly.

He likes it very much.

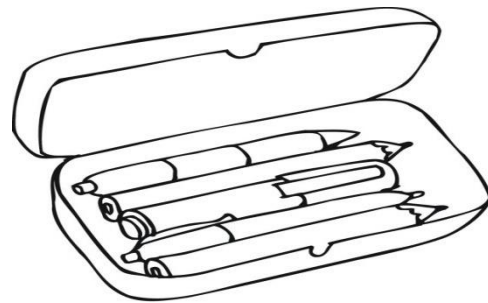

Now write similar sentences about your pencil box :

This is my pencil box.

It is green in colour

My father bought it for me

I bring it to school daily.

I like it very



much.

Comprehension : (Reading)

The Goose and its golden egg



Once there lived a poor farmer. He had a goose. It laid a golden egg every day. The farmer sold the eggs and became rich. He was a greedy farmer. He wanted all the golden eggs at the same time. So he took a knife and cut the goose but there were no eggs in it. Thus the greedy farmer lost both the goose and the golden eggs and became poor again.

Answer the following:

1. What did the farmer have?

A. The farmer had a goose.

2. What did it lay every day?

A. It laid a golden egg every day.

3. How did the farmer become rich?

A. The farmer sold the eggs and became rich.

4. Who lost both the goose and the golden eggs?

A. The greedy farmer.

STORY WRITING :

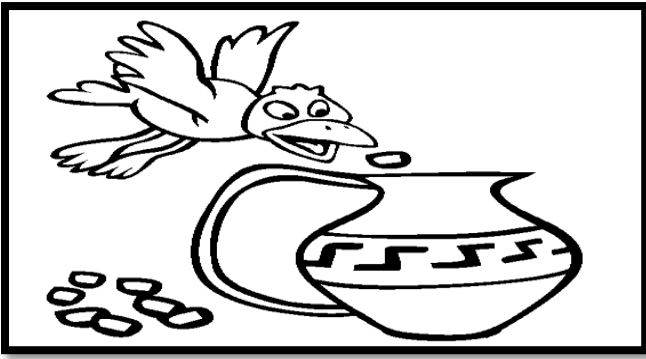

Some thirsty big hot little
clever round cool happy bottom

It is a _____ day. Kaku, the crow , is very _____. He wants _____
water. He sees a _____ pot with a _____ water at the _____.
The _____ crow drops _____ pebbles into the pot. The _____
water comes up and the crow slips it. How _____ he is now !.